



U.S. DEPARTMENT OF ENERGY WASTE ISOLATION PILOT PLANT

REMOTE-HANDLED TRANSURANIC WASTE

After 5,000 safe shipments of contact-handled transuranic waste, WIPP started receiving remote-handled transuranic waste.

In October 2006, the New Mexico Environment Department (NMED) approved the U.S. Department of Energy's plans for disposal of remote handled (RH) transuranic (TRU) waste at the Waste Isolation Pilot plant (WIPP). The Environmental Protection Agency (EPA) gave its approval in 2004.

Located in the remote desert of southeastern New Mexico, WIPP permanently isolates barrels and boxes of TRU waste from the nation's nuclear weapons program 2,150 feet underground in an ancient salt bed.

WIPP was designed to dispose of both contact handled (CH)- and RH-TRU waste, as addressed

The specially designed RH-72B cask is constructed of steel, shielded by lead and protected by sturdy impact limiters at both ends. The RH-72B holds up to three 55-gallon drums or a single cylindrical canister of waste.



DID YOU KNOW...

AS WITH CH-TRU WASTE, ALL RH-TRU SHIPMENTS UNDERGO A COMMERCIAL VEHICLE SAFETY ALLIANCE LEVEL VI INSPECTION, THE MOST RIGOROUS IN THE SHIPPING INDUSTRY.

in WIPP's first environmental impact statement in 1980 and the 1992 federal WIPP Land Withdrawal Act.

Only about 4 percent - or 7,080 cubic meters - of the total volume of waste received at WIPP is expected to be RH-TRU, according to a 1981 Department of Energy record of decision and a 1988 agreement with the State of New Mexico. The total volume of waste anticipated at WIPP is 175,570 cubic meters, as stipulated by the Land Withdrawal Act.

While RH-TRU waste will be a small percentage of the total amount of waste at WIPP, its disposal is essential to addressing the environmental legacy of the Cold War.

Just like CH-TRU waste, RH-TRU waste disposed of at WIPP consists of tools, rags, protective clothing, sludges, soil and other materials contaminated with radioactive elements that

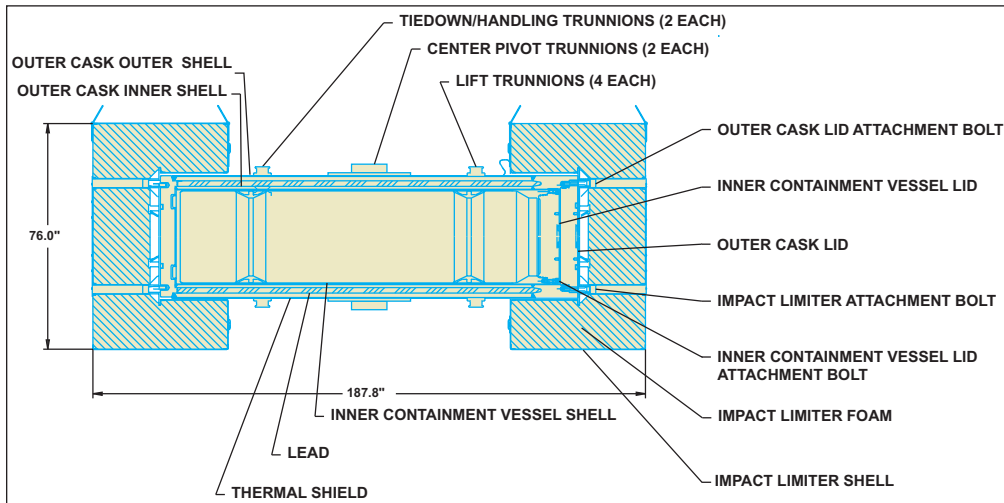

RH-TRU waste is disposed in the walls of the disposal rooms using shielded horizontal emplacement equipment.

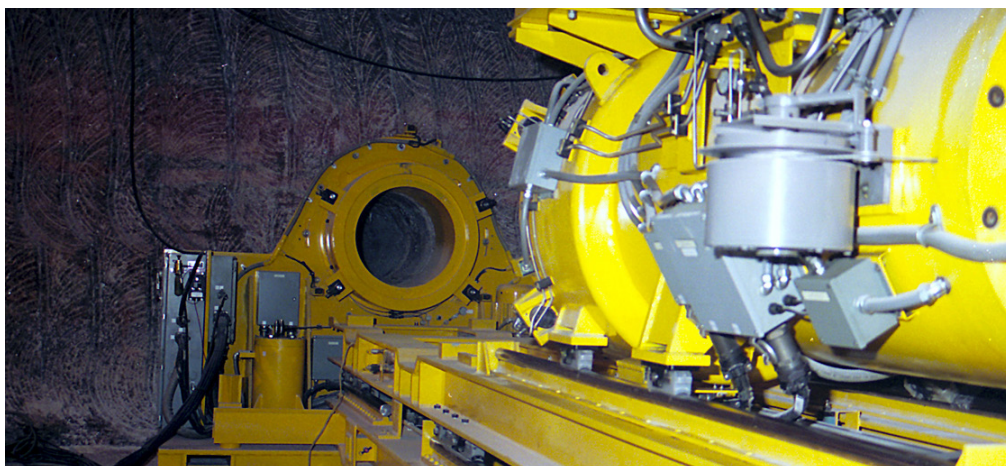

have atomic numbers greater than uranium (transuranic).

When transported, RH- and CH-TRU waste have the same dose rate limit on the outside of the shipping casks.

FOR MORE INFORMATION

WIPP INFORMATION CENTER
 U.S. DEPARTMENT OF ENERGY
 CARLSBAD FIELD OFFICE
 P.O. BOX 2078, CARLSBAD, NM 88221
 1-800-336-WIPP (9477)
 INFOCNTR@WIPP.WS
 WWW.WIPP.ENERGY.GOV
 FACEBOOK.COM/WIPPNEWS
 @WIPPNEWS

Before any waste generator site ships RH-TRU waste to WIPP, the EPA and NMED must approve the site's procedures for characterization, determining the physical and chemical characteristics of the waste, to ensure it is suitable for disposal at WIPP.

Transportation

RH-TRU waste is transported to WIPP primarily in the RH-72B. The shipping cask has also been used to safely ship RH-TRU waste between waste generator sites.

The Nuclear Regulatory Commission has certified the cask, following rigorous safety testing to ensure it would remain leak tight, even in a severe accident.

The RH-72B cask is constructed of steel and capped with impact limiters, which are designed to act as shock absorbers. The RH-72B holds up to three 55-gallon drums or a single cylindrical canister of waste. Because of the weight of lead shielding, only one RH cask is loaded per trailer, compared to up to three TRUPACT-IIs and HalfPACTs used for CH-TRU waste.

Transportation routes to WIPP for RH- and CH-TRU waste are the same. Routes are designated in cooperation with states and tribal nations. Shipments are tracked by satellite from a secure, around-the-clock control center.

As with CH-TRU waste, all RH-TRU shipments undergo a Commercial Vehicle Safety Alliance Level VI inspection, the most rigorous in the shipping industry, and drivers must also stop and perform an inspection every three hours or 150 miles. Truck drivers must meet stringent requirements to be qualified to transport waste to WIPP.

Since 1998, more than 25,000 emergency responders along WIPP routes have received free training.

At WIPP

RH-TRU waste canisters are primarily placed in boreholes drilled into the walls of WIPP's underground disposal rooms. CH-TRU waste barrels and boxes are then stacked in rows on the floor of the same rooms.

In an RH-72B, waste or drums of waste are inside of a cylindrical canister, which is loaded into a facility cask at WIPP. Once underground, a forklift moves the facility cask to horizontal emplacement equipment, which pushes the canister out of the facility cask and into a borehole, and then inserts a concrete shield plug.